

# DPP/3DPP

Digital ProcessPower UPS

INDUSTRIAL PWM  
UNINTERRUPTIBLE  
POWER SUPPLY  
SYSTEM

SINGLE PHASE  
THREE PHASE



**AMETEK**<sup>®</sup>

SOLIDSTATE CONTROLS

PROVIDING CONTINUITY OF ELECTRICAL POWER

# DPP/3DPP

## DIGITAL PROCESS POWER

### Industrial Pulse Width Modulated Uninterruptible Power Supply System

DPP SINGLE PHASE 5-100 kVA

3DPP THREE PHASE 10-225 kVA



The Digital ProcessPower (DPP) Uninterruptible Power Supply (UPS) system from AMETEK Solidstate Controls is a true on-line, double conversion UPS system that provides continuous, clean, regulated power for critical AC loads. Designed specifically for process control and industrial applications, the DPP systems utilize state of the art Pulse Width Modulation (PWM) technology. PWM incorporates high power IGBT semiconductors and digital control for enhanced communications, monitoring, control and diagnostics capabilities.

Also essential to the DPP design is the use of fiber optic cables for control and communications; allowing for better isolation and faster, more accurate signals between processors. The DPP designs also include an LCD panel and user-friendly touch screen display for the ultimate in user control.

- True on-line, double conversion UPS
- Provides continuous, clean, regulated power for critical AC loads
- High power IGBT semiconductors and digital control
- Fiber optic cables used for control and communications
- LCD panel and user-friendly touch screen display
- Digital ProcessPower has lower audible noise

# The Power Behind the Process

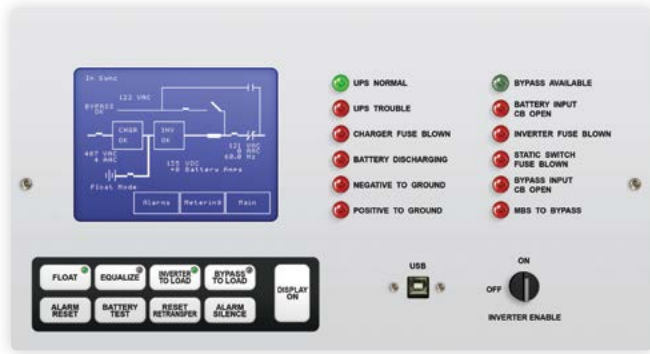

## PROCESSPOWER UPS SYSTEM LCD AND TOUCH SCREEN USER PANEL

Shown with optional indicator lights

### Keypad Controls and Switches

- Float/Equalize Initialization with Light
- Battery Test Initialization
- Inverter to Load with Light
- Bypass to Load with Light
- Static Switch Reset Retransfer
- Latching Alarm Reset
- Audible Alarm Silence
- Display On
- Inverter Enable (On/Off) Switch

\*Standard LED Indicators: UPS Normal and UPS Trouble

### Standard LCD Panel Indicators

- Equalize Time Remaining
- Charger Status (OK/Fail)
- Float/Equalize Status
- Inverter Status (OK/Fail)
- Synchronism Status (In/Out of Sync)
- Static Switch Position (Inverter or Bypass)
- Manual Bypass Position (Normal or Bypass)
- Bypass Status (OK/Fail)

## New Option! The Slimmer DPP

Our single phase DPP system is now available in a compact slimmer cabinet while maintaining the reliability and quality you expect from AMETEK. This is designed for off-shore platforms and space-sensitive applications.

**Save 8" in width and 8.5" in depth. The slimmer DPP offers the smallest footprint for industrial UPS systems!**

**Width 24" x Depth 27.5" x Height 79"**

The slimmer DPP seamlessly connects with an optional remote manual bypass switch, which can either be mounted on a wall or paired with an isolation bypass transformer in a separate slimmer cabinet. These units are top cable entry only and come with a maintenance bypass switch.

Input Parameters	
AC Input Voltage	208, 480 VAC
AC Input Phase	3 Ø
AC Input Frequency	60/50 Hz
AC Voltage Tolerance	± 10%
DC Bus Voltage	125, 240 VDC
Output Parameters	
Output Power	5-20 kVA
Power Factor	0.8
AC Output Voltage	120 VAC
AC Output Phase	1 Ø
AC Output Frequency	60/50 Hz

System Configuration	
AC Input Breaker	
Bypass Input Breaker	
Battery Input Breaker	
Optional AC Output Breaker	
Optional AC Output Breaker	
Top-Cable Entry ONLY	
6 or 12-Pulse Rectifier/Charger	
Make-Before-Break Static Switch	
Optional Remote Manual Bypass Switch (3 position) <sup>1</sup>	

<sup>1</sup> Manual Bypass Switch must be in external enclosure with this cabinet style



# DPP Specifications

## 0.8 Load Power Factor at Rated kVA 120 VDC (60 Lead Acid Battery Cells)

Model Number	Rated Output Power		Efficiency		AC Input/Freq. AC Amps per Phase <sup>1</sup>			Max DC Current	AC Output Amps <sup>1</sup>			UPS Cabinet Style	Weight <sup>2</sup>		Heat Loss (BTU/hr)
	kVA	kW	AC-DC	DC-AC	480/60	208/60	380/50		@ 1.75 VPC	120	220		240	lb	
DPP005-3	5	4	92%	87%	11	25	14	44	42	23	21	GTDX	765	347	3,403
DPP007-3	7.5	6	92%	87%	16	37	20	66	63	34	31	GTDX	930	422	5,105
DPP010-3	10	8	92%	87%	21	48	26	88	83	46	42	GTDX	1,100	499	6,807
DPP015-3	15	12	92%	87%	31	70	39	131	125	68	63	GTDX	1,300	590	10,210
DPP020-3	20	16	93%	87%	40	92	50	175	167	91	83	GTDX	1,500	680	12,881
DPP030-3	30	24	93%	87%	59	137	75	263	250	136	125	GTDX	1,950	885	19,321
DPP040-3	40	32	93%	87%	78	181	99	350	333	182	167	GTDX	2,050	930	25,761
DPP050-3	50	40	93%	87%	99	228	125	438	417	227	208	GTDX	2,150	975	32,201

## 0.8 Load Power Factor at Rated kVA 240 VDC (120 Lead Acid Battery Cells)

Model Number	Rated Output Power		Efficiency		AC Input/Freq. AC Amps per Phase <sup>1</sup>			Max DC Current	AC Output Amps <sup>2</sup>			UPS Cabinet Style	Weight <sup>2</sup>		Heat Loss (BTU/hr)
	kVA	kW	AC-DC	DC-AC	480/60	208/60	380/50		@ 1.75 VPC	120	220		240	lb	
DPP030-3	30	24	93%	89%	58	134	73	128	250	136	125	GTDX	1,950	885	17,046
DPP040-3	40	32	94%	89%	76	176	97	171	333	182	167	GTDX	2,050	930	21,325
DPP050-3	50	40	94%	89%	96	220	121	214	417	227	208	GTDX	2,150	975	26,657
DPP060-3	60	48	94%	89%	119	276	151	257	500	273	250	GTDX	2,550	1,157	31,988
DPP080-3	80	64	94%	89%	153	353	193	342	667	364	333	GTDX	3,400	1,542	42,650
DPP100-3	100	80	94%	89%	191	441	241	428	833	455	417	GTDX	4,900	2,227	53,313

## 1.0 Load Power Factor at Rated kVA 120 VDC (60 Lead Acid Battery Cells)

Model Number	Rated Output Power		Efficiency		AC Input/Freq. AC Amps per Phase <sup>1</sup>			Max DC Current	AC Output Amps <sup>1</sup>			UPS Cabinet Style	Weight <sup>2</sup>		Heat Loss (BTU/hr)
	kVA	kW	AC-DC	DC-AC	480/60	208/60	380/50		@ 1.75 VPC	120	220		240	lb	
DPP005-3	5	5	92%	87%	15	35	20	55	42	23	21	GTDX	940	426	4,254
DPP007-3	7.5	7.5	92%	87%	20	47	26	82	63	34	31	GTDX	1,105	501	6,382
DPP010-3	10	10	92%	87%	30	70	39	109	83	45	42	GTDX	1,300	590	8,509
DPP015-3	15	15	92%	87%	40	93	51	164	125	68	63	GTDX	1,500	680	12,075
DPP020-3	20	20	93%	87%	60	139	76	219	167	91	83	GTDX	1,950	885	16,101
DPP030-3	30	30	93%	87%	81	187	102	328	250	136	125	GTDX	2,050	930	24,151
DPP040-3	40	40	93%	87%	99	228	125	438	333	182	167	GTDX	2,150	975	32,201

## 1.0 Load Power Factor at Rated kVA 240 VDC (120 Lead Acid Battery Cells)

Model Number	Rated Output Power		Efficiency		AC Input/Freq. AC Amps per Phase <sup>1</sup>			Max DC Current	AC Output Amps <sup>1</sup>			UPS Cabinet Style	Weight <sup>2</sup>		Heat Loss (BTU/hr)
	kVA	kW	AC-DC	DC-AC	480/60	208/60	380/50		@ 1.75 VPC	120	220		240	lb	
DPP030-3	30	30	93%	89%	77	178	98	161	250	136	125	GTDX	2,050	930	19,992
DPP040-3	40	40	94%	89%	96	220	121	214	333	182	167	GTDX	2,150	975	26,657
DPP050-3	50	50	94%	89%	119	276	151	268	417	227	208	GTDX	2,550	1,157	33,321
DPP060-3	60	60	94%	89%	153	353	193	321	500	273	250	GTDX	3,400	1,542	39,985

### Model Coding

"DD"	"EE"	"FF"	"GG"	"HH"	"I"	"J"
AC Input Volts (code)	DC Bus Volts (code)	AC Output Volts (code)	Freq (code)	Output Power Factor (code)	Charger Design (code)	Config Code (code)
208 - (20)	120 - (12)	120 - (12)	60 - (60)	0.8 - (K)	6-Pulse - (S)	Float - (F)
480 - (48)	240 - (24)	220 - (22)	50 - (50)	1.0 - (W)	12-Pulse - (T)	Parallel (P)
380 - (38)		240 - (24)				
600 - (60)						

<sup>1</sup> Circuit Breakers are sized at a minimum of 125% of rated current.

<sup>2</sup> Unit weights correspond to a 60 Hz unit. Contact us for 50 Hz unit weight.

<sup>3</sup> A complete model number includes the AC input voltage, DC bus (link) voltage, AC output voltage, system frequency, output power factor, and UPS configuration. To "build" a model number, use the "code" in the matrix shown above, following the example format: DPP010-DD-EE-FF-GG-H-I-J, where DD=AC Input Voltage; EE=DC bus voltage; FF=AC Output Voltage; GG=System Frequency; H=Output Power Factor ('K' for 0.8; 'W' for 1.0); I=6(S) or 12(T) Pulse Charger design; J=UPS configuration ('F' for Float, 'P' for Parallel Redundant).

For Example: A 20 kVA with 480 VAC input; 120 VDC bus voltage; 120 VAC output; 60 Hz; 0.8 output power factor; 6 pulse charger; Float system would have the following model number: DPP020-48-12-12-60-K-S-F. For custom systems and for units which do not have a configurable model number, insert a 'C' in the model number as follows: DPP020C

Sizes are subject to change. Top mounted cooling fans require 0.5 in (13 mm) additional height. Certain optional features and/or combinations may require larger cabinets.

### Cabinet Dimensions Inches Millimeters

Style	H x W x D	H x W x D
GTDX	79 x 32 x 36	2,007 x 813 x 914
GTDX	79 x 54 x 36	2,007 x 1,372 x 914
GTDX	79 x 86 x 36	2,007 x 2,184 x 914
GTDX	79 x 108 x 36	2,007 x 2,743 x 914
GTDX	79 x 140 x 36	2,007 x 3,557 x 914

STAND-ALONE UPS CONFIGURATION

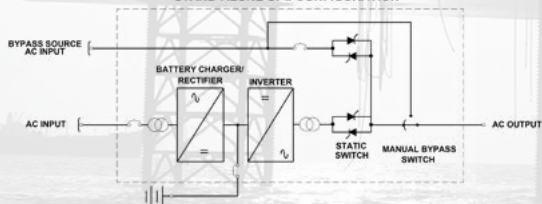

PARALLEL REDUNDANT CONFIGURATION

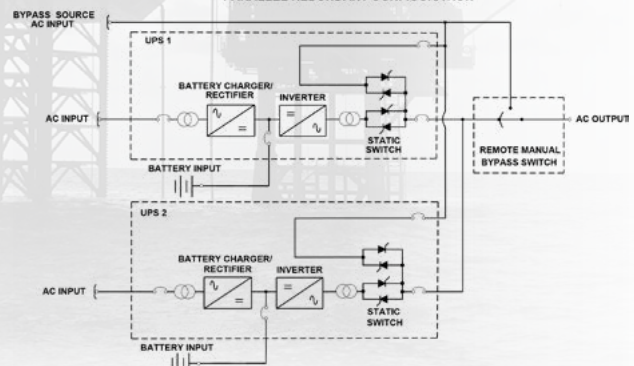



# 3DPP Specifications

## 0.8 Load Power Factor at Rated kVA 120VDC (60 Lead Acid Battery Cells)

Model Number	Rated Output Power		Efficiency		3PH AC Input/Freq AC Amps Per Phase <sup>1</sup>				Max DC Current	3PH AC Output Amps Per Phase <sup>1</sup>			Cabinet Style	Weight <sup>2</sup>		Heat Loss (BTU/hr)
	kVA	kW	AC-DC	DC-AC	208/60	480/60	600/60	380/50		208	480	380		lb	kg	
3DPP010- <sup>3</sup>	10	8	92%	87%	48	21	17	26	88	28	12	15	CTD1X	1,100	499	6,807
3DPP015- <sup>3</sup>	15	12	92%	87%	70	31	24	39	131	42	18	23	CTD1X	1,300	590	10,210
3DPP020- <sup>3</sup>	20	16	93%	87%	92	40	32	50	175	56	24	30	CTD1X	1,500	680	12,880
3DPP030- <sup>3</sup>	30	24	93%	87%	137	59	47	75	263	83	36	46	CTD2X	1,950	885	19,321
3DPP040- <sup>3</sup>	40	32	93%	87%	181	78	63	99	350	111	48	61	CTD2X	2,050	930	25,761
3DPP050- <sup>3</sup>	50	40	93%	87%	228	99	79	125	438	139	60	76	CTD3X	2,150	1,315	32,201

## 0.8 Load Power Factor at Rated kVA 240VDC (120 Lead Acid Battery Cells)

Model Number	Rated Output Power		Efficiency		3PH AC Input/Freq AC Amps Per Phase <sup>1</sup>				Max DC Current	3PH AC Output Amps Per Phase <sup>1</sup>			Cabinet Style	Weight <sup>2</sup>		Heat Loss (BTU/hr)
	kVA	kW	AC-DC	DC-AC	208/60	480/60	600/60	380/50		208	480	380		lb	kg	
3DPP030- <sup>3</sup>	30	24	93%	89%	134	58	46	73	128	83	36	46	CTD1X	1,950	885	17,046
3DPP040- <sup>3</sup>	40	32	94%	89%	176	76	61	97	171	111	48	61	CTD2X	2,050	930	21,325
3DPP050- <sup>3</sup>	50	40	94%	89%	220	96	77	121	214	139	60	76	CTD2X	2,150	975	26,657
3DPP060- <sup>3</sup>	60	48	94%	89%	276	119	96	151	257	167	72	91	CTD2X	2,550	1,157	31,988
3DPP080- <sup>3</sup>	80	64	94%	89%	353	153	122	193	342	222	96	122	CTD2X	3,400	1,452	42,650
3DPP100- <sup>3</sup>	100	80	94%	89%	441	191	153	241	428	278	120	152	CTD4X	4,400	1,996	53,313
3DPP125- <sup>3</sup>	125	100	94%	89%	551	239	191	302	535	347	151	190	CTD4X	4,900	2,227	66,641
3DPP160- <sup>3</sup>	160	128	94%	89%	708	307	245	387	685	444	192	243	CTD4X	5,880	2,667	85,301

## 0.8 Load Power Factor at Rated kVA 360VDC (180 Lead Acid Battery Cells)

Model Number	Rated Output Power		Efficiency		3PH AC Input/Freq AC Amps Per Phase <sup>1</sup>				Max DC Current	3PH AC Output Amps Per Phase <sup>1</sup>			UPS Cabinet Style	Weight <sup>2</sup>		Heat Loss (BTU/hr)
	kVA	kW	AC-DC	DC-AC	208/60	480/60	600/60	380/50		208	480	380		lb	kg	
3DPP200- <sup>3</sup>	200	160	94%	89%	885	383	307	484	571	555	241	304	CTD5X	7,060	3,203	106,626
3DPP225- <sup>3</sup>	225	180	94%	89%	995	431	345	545	642	625	271	342	CTD5X	8,470	3,842	119,954

## 1.0 Load Power Factor at Rated kVA 120VDC (60 Lead Acid Battery Cells)

Model Number	Rated Output Power		Efficiency		3PH AC Input/Freq AC Amps Per Phase <sup>1</sup>				Max DC Current	3PH AC Output Amps Per Phase <sup>1</sup>			UPS Cabinet Style	Weight <sup>2</sup>		Heat Loss (BTU/hr)
	kVA	kW	AC-DC	DC-AC	208/60	480/60	600/60	380/50		208	480	380		lb	kg	
3DPP010- <sup>3</sup>	10	10	92%	87%	70	31	24	39	110	28	12	15	CTD1X	1,300	590	8,509
3DPP015- <sup>3</sup>	15	15	93%	87%	92	40	32	50	164	42	18	23	CTD1X	1,500	680	12,075
3DPP020- <sup>3</sup>	20	20	93%	87%	137	59	47	75	219	56	24	30	CTD2X	1,950	885	16,101
3DPP030- <sup>3</sup>	30	30	93%	87%	181	78	63	99	328	83	36	46	CTD2X	2,050	930	24,151
3DPP040- <sup>3</sup>	40	40	93%	87%	228	99	79	125	438	111	48	61	CTD3X	2,150	975	32,201

## 1.0 Load Power Factor at Rated kVA 240VDC (120 Lead Acid Battery Cells)

Model Number	Rated Output Power		Efficiency		3PH AC Input/Freq AC Amps Per Phase <sup>1</sup>				Max DC Current	3PH AC Output Amps Per Phase <sup>1</sup>			UPS Cabinet Style	Weight <sup>2</sup>		Heat Loss (BTU/hr)
	kVA	kW	AC-DC	DC-AC	208/60	480/60	600/60	380/50		208	480	380		lb	kg	
3DPP030- <sup>3</sup>	30	30	94%	89%	176	76	61	97	161	83	36	46	CTD2X	2,050	930	19,992
3DPP040- <sup>3</sup>	40	40	94%	89%	220	96	77	121	214	111	48	61	CTD2X	2,150	975	26,657
3DPP050- <sup>3</sup>	50	50	94%	89%	276	119	95	151	268	139	60	76	CTD2X	2,550	1,157	33,321
3DPP060- <sup>3</sup>	60	60	94%	89%	353	153	122	193	321	167	72	91	CTD2X	3,400	1,542	39,985
3DPP080- <sup>3</sup>	80	80	94%	89%	441	191	153	241	428	222	96	122	CTD4X	4,400	1,996	53,313
3DPP100- <sup>3</sup>	100	100	94%	89%	551	239	191	302	535	278	120	152	CTD4X	4,900	2,227	66,641

### Model Coding

"DD"	"EE"	"FF"	"GG"	"HH"	"I"	"J"
AC Input Volts (code)	DC Bus Volts (code)	AC Output Volts (code)	Freq (code)	Output Power Factor (code)	Charger Design (code)	Config Code (code)
208 - (20)	120 - (12)	120/208 - (20)	60 - (60)	0.8 - (K)	6-Pulse - (S)	Float - (F)
480 - (48)	240 - (24)	277/480 - (48)	50 - (50)	1.0 - (W)	12-Pulse - (T)	Parallel (P)
600 - (60)	360 - (36)	220/380 - (38)				
380 - (38)						

<sup>1</sup> Circuit Breakers are sized at a minimum of 125% of rated current.

<sup>2</sup> Unit weights correspond to a 60 Hz unit. Contact us for 50 Hz unit weight.

<sup>3</sup> A complete model number includes the AC input voltage, DC bus (link) voltage, AC output voltage, system frequency, output power factor, and UPS configuration. To "build" a model number, use the "code" in the matrix shown above, following the example format: 3DPP010-DD-EE-FF-GG-H-I-J; where DD=AC Input Voltage, EE=DC bus voltage, FF=AC Output Voltage, GG=System Frequency, H=Output Power Factor ('K' for 0.8, 'W' for 1.0); I=(S) or I(T) Pulse Charger design; J=UPS configuration ('F' for Float, 'P' for Parallel Redundant).

For Example: A 20 kVA with 480 VAC input, 120 VDC bus voltage, 120/208 VAC output, 60 Hz, 0.8 output power factor, 6 pulse charger, Float system would have the following model number: 3DPP020-48-12-20-60-K-S-F. For custom systems and for units which do not have a configurable model number, insert a 'C' in the model number as follows: 3DPP020C

Sizes are subject to change. Top mounted cooling fans require 0.5 in (13 mm) additional height. Certain optional features and/or combinations may require larger cabinets.

### Cabinet Dimensions Inches Millimeters

Style	H x W x D	H x W x D
CTD1X	79 x 32 x 36	2,007 x 813 x 914
CTD2X	79 x 54 x 36	2,007 x 1,372 x 914
CTD3X	79 x 86 x 36	2,007 x 2,184 x 914
CTD4X	79 x 108 x 36	2,007 x 2,743 x 914
CTD5X	79 x 140 x 36	2,007 x 3,557 x 914

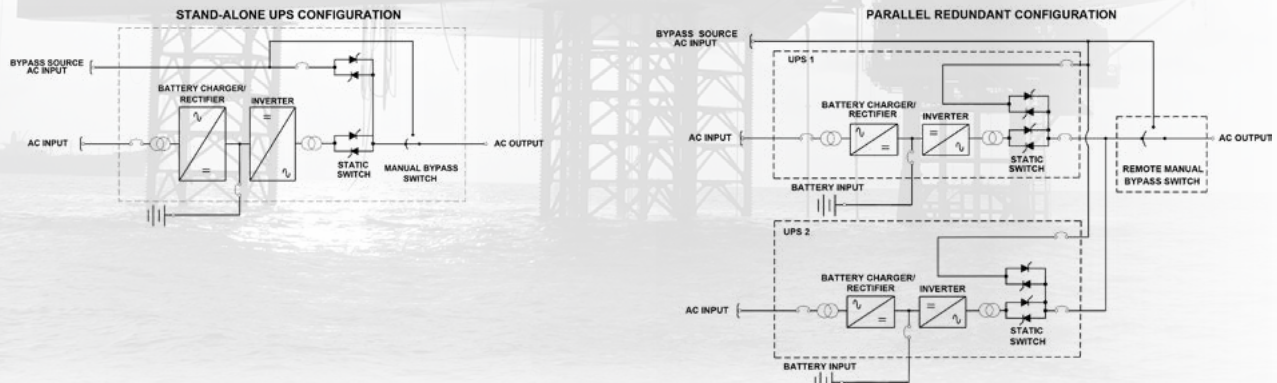



# SERVICE OPTIONS

AMETEK Solidstate Controls' products are known for their high quality. To keep them running smoothly, do not trust the maintenance of them to just anyone. No one will have the in-depth knowledge and familiarity as we do. We care about our products and we provide superior service agreements that ensure your critical power equipment continuously functions as designed.

We offer three levels of multi-year service agreements, designed to support our preventative maintenance schedules.

General Services	Basic	CSA <sup>1</sup>	CSA+ <sup>1</sup>
Pre-Inspection Interview	Annually	Annually	Annually
Post-Inspection Interview	Annually	Annually	Annually
Detailed Service Report	Annually	Annually	Annually
UPS/Inverter/Charger Services	Basic	CSA	CSA+
Visual Inspection	Annually	Annually	Annually
Scheduled Parts Replacement	Every 5 Years	Annually	Annually
System Operational and Functional Testing	Every 5 Years	Annually	Annually
Infrared Scanning/Thermal Imaging	Optional	Annually	Annually
Battery Inspection & Continuity Test	Basic	CSA	CSA+
Visual Inspection	Annually	Annually	Annually
Individual Cell Voltages	Every 5 Years	Annually	Annually
Continuity Test	Every 5 Years	Annually	Annually
Inter-cell resistance	Optional	Optional	Annually
Specific Gravity	Optional	Optional	Annually
System AC Load testing	Optional	Optional	Annually
Battery Capacitance Discharge Testing per IEEE Recommended Schedule	Optional	Optional	Optional
Parts and Service Coverage	Basic	CSA	CSA+
Emergency Service Fee	Waived	Waived	Waived
Guaranteed Emergency Response Time	Not Specified	72 Hours <sup>2</sup>	24 Hours <sup>2</sup>
Minimum Repair Service Cost per Repair Trip	Waived	Waived	Waived
Parts Covered Under Warranty	Only PM parts covered	All Parts in System	All Parts in System
Transformers (Less than 20 years)	No Coverage	Covered	Covered
Travel and Living Expenses	Billed at cost	Covered	Covered
Labor	Standard Rates	Covered	Covered
Replacement System Manuals	\$350 each	\$175 each	No Cost
Financial Benefits	Basic	CSA	CSA+
Spare Parts Discount	5%	15%	20%
Annualized Pricing	Included	Included	Included
Discount on Training Seminars	None	25%	50%

<sup>1</sup> CSA and CSA+ meet factory recommended guidelines for preventative maintenance

<sup>2</sup> System restored to safe and stable condition

## WORLD HEADQUARTERS

875 Dearborn Drive  
Columbus, Ohio 43085  
Phone: +1-614-846-7500  
Toll Free: +1-800-635-7300  
Fax: +1-614-885-3990

## GLOBAL OFFICES LOCATED IN

Mexico Middle East  
Asia Pacific India  
Brazil Argentina

## WEBSITE

[www.solidstatecontrolsinc.com](http://www.solidstatecontrolsinc.com)

## EMAIL

[SCI.sales@AMETEK.com](mailto:SCI.sales@AMETEK.com)



**AMETEK**<sup>®</sup>  
**SOLIDSTATE CONTROLS**

REV 12/2018

THE PURPOSE OF OUR BUSINESS IS TO PROVIDE CONTINUITY OF ELECTRICAL POWER TO KEEP BUSINESSES IN BUSINESS.

WE DO THIS BY HELPING CLIENTS SOLVE THEIR POWER PROBLEMS AND BY CREATING THE MOST ECONOMICAL LONG-TERM RESULTS.